

locktronics

Simplifying Electricity

Introduction to motors, generators and hybrid

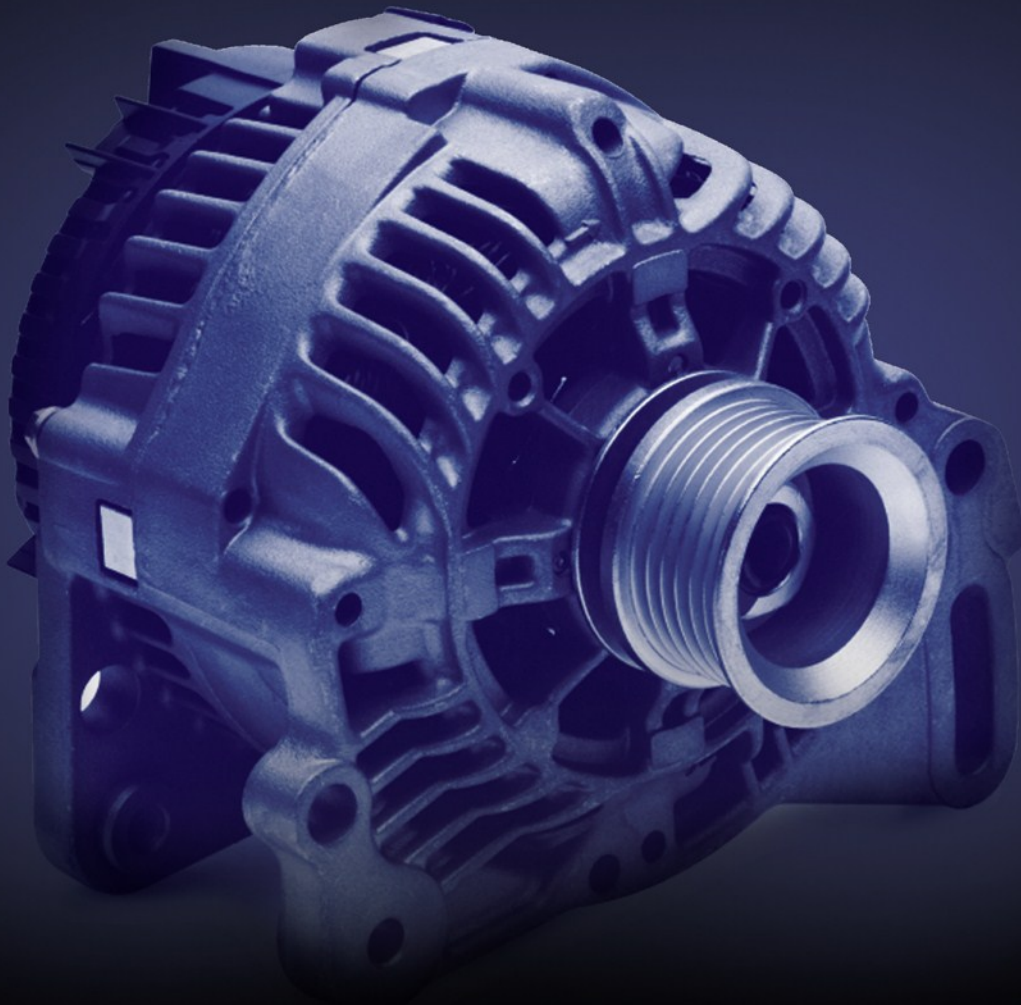

LK8822

MATRIX
www.matrixmultimedia.com

Copyright © 2009 Matrix Multimedia Limited

Contents

Introduction to motors, generators and hybrid

Worksheet 1 - Motor principles	3
Worksheet 2 - The electric motor	5
Worksheet 3 - Generator principles	7
Worksheet 4 - Hybrid principles	9
Worksheet 5 - Generating electricity - a closer look	11
Worksheet 6 - Transformers	13
Worksheet 7 - Practical transformers	15
Worksheet 8 - Half-wave rectifier	17
Worksheet 9 - Full-wave rectifier	19
Worksheet 10 - The zener diode	21
Instructor Guide	23
Picoscope Help	31

About this document:

Code: LK8822

Developed for product code LK7445– An introduction to motors, generators and hybrid

Date	Release notes	Release version
31 10 2012	First release for LK8445 solution	LK8822-80-1

Worksheet 1

Motor principles

Introduction to motors, generators and hybrid



Electric motors come in all shapes and sizes. Some run off DC power, others need AC.



There are brushed and brushless, single phase and three phase, induction, synchronous, stepper ,servo, and many more.



In the car, they:

- start the engine,
- operate the windows,
- wipe the windscreen,
- run the fan,
- pump the washers, raise the radio aerial, adjust the driver's seat



They can even power the whole car. All rely on the same physical principle, investigated here



Over to you:

- This investigation uses the Motor-effect carrier, shown opposite. It has two fixed conductors, with a moveable metal rod sitting on top, across them.
- Build the system shown in the second picture. For clarity, the magnet has not been pushed right over the metal rod.
- Push it right across, so that the moveable rod sits in the middle of the magnetic field.
- The power supply is set to 3V.
- Press the push switch, and notice what happens.
- Next, flip the magnet over so that the South pole is on top.
- Press the push switch again. What is the difference?
- Reverse the current direction by rotating the power supply carrier so that the negative end (short line on the symbol) is at the top.
- What happens now when you press the push switch?
- Change the power supply voltage to 13.5V. This should increase the current flowing through the rod.
- Can you see any difference when you close the push switch?

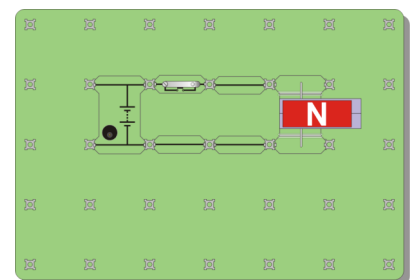

Worksheet 1

Motor principles

Introduction to motors, generators and hybrid

So what?

Here's the underlying theory:

- a current is a flow of electrons, tiny negatively-charged 'particles' found in all atoms;
- when electrons move, they generate a magnetic field;
- this interacts with the field of the ceramic magnets, causing attraction / repulsion, except that it acts at right-angles to the current direction and to the magnetic field.

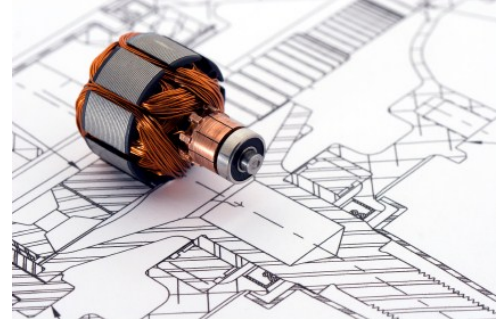

Fleming's Left-hand Rule:

John Ambrose Fleming devised a way to work out the direction a wire will move in (also known as the *motor rule*):

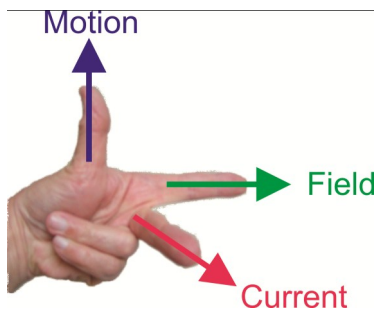

Clamp your **left**-hand to the corner of an imaginary box, so that thumb, fore finger and centre finger are all at right-angles to each other. Then, line up the **F**ore finger points along the magnetic **F**ield (from North pole to South pole,) and line up the **C**entre finger with the **C**urrent (from positive battery terminal to negative.) The **th**u**M**b now points in the direction of the resulting **M**otion.

For your records:

Copy and complete the following, using your observations from the investigation:

- The magnetic field exerts a force on a conductor which is at-angles to the direction of the and to the direction of the
- When the magnetic field is reversed, the is reversed.
- When the current is reversed, the is reversed.
- Increasing the current, increases the

Complete the following version of Fleming's motor rule:

- Using the hand, hold the thumb, fore finger and centre finger at to each other.
- Keeping this shape, move the hand until the fore finger points in the direction of the, (from to) and the centre finger points in the direction of the (from to)
- The thumb now points in the direction of

Worksheet 2

The electric motor

Introduction to motors, generators and hybrid

Electric motors usually consist of a coil rotating inside the magnetic field of either a permanent magnet or an electromagnet. They rotate because the current reverses at just the right time.

There are two problems to be solved then:

- making electrical connections to a rotating coil;
- reversing the current at the right time.

Two solutions are:

- use slip rings with an AC supply;
- use a commutator and carbon brushes with a DC supply.

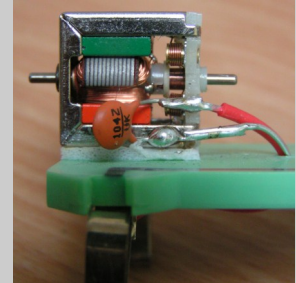

w2a

Over to you:

This investigation uses any of the three Locktronics DC motors. They use a commutator and carbon brushes.

- Build the system shown opposite with a 6V power supply. Press the push switch, and watch the ammeter reading.
- Next, keep the push-switch closed, and press gently on the motor shaft, or against the plastic wheel attached to it, to slow down the motor. Watch the ammeter reading as you do so.
- Press the push switch again. Press on the shaft or on the wheel to stop the motor rotating for a moment. Again watch the ammeter reading as you do so.
- Copy the table, and complete it with your measurements.

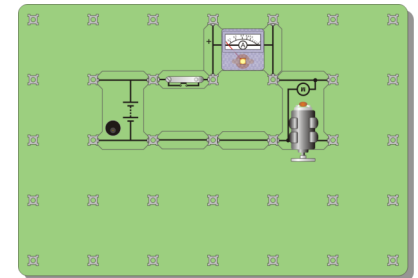

w2b

Motor speed	Current in A
Maximum	
Slow	
Zero	

So what?



Most motors rotate, so how does that happen?

The top diagram shows a cutaway coil of wire, disappearing into the sheet of paper. There is a magnetic field from left to right. Current flows into the paper on the left side of the coil, and out of the paper on the right.

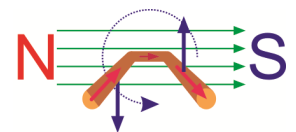

w2d

Using the Left-hand rule, the coil sides move in the directions shown by the blue arrows, and so the coil starts to rotate. (There is no force on the back of the coil, because there current flows parallel, not at right-angles, to the magnetic field.)

When the coil reaches the position shown in the second diagram, there is no twisting effect as the forces on the sides are in line, but in opposite directions. Momentum carries it past that position.

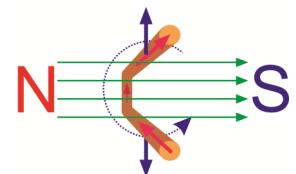

w2e

We now reverse the current, so that when the coil reaches the position shown in the third diagram, the forces keep it rotating.

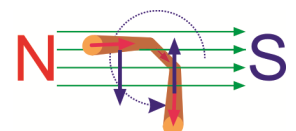

w2f

Provided the current reverses again at the right time, rotation continues.

Worksheet 2

The electric motor

Introduction to motors, generators and hybrid

So what?

There are two ways to reverse the current:

1. use **slip-rings** with brushes:

The picture shows one form of slip-ring.

Each end of the coil is connected to its own full brass ring.

Electrical contact is made to each ring with a carbon brush, which moulds itself to the shape of the ring, reducing contact resistance.

The coil is supplied with AC, and so the current automatically changes direction in step with the mains supply.



w2g

2. use a **commutator** with brushes:

The diagram shows the design of a simple commutator, a brass drum, split into two halves, separated by an insulator.

Electrical contact is made by carbon brushes.

The coil is connected to the two halves at X and Y.

As the coil rotates, X is connected to the positive supply for roughly half of the time, and then to the negative supply. At all times, Y is connected to the opposite supply to X.

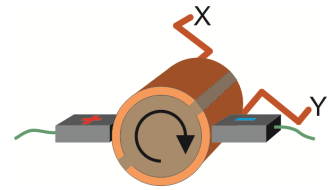

w2h

The pictures show a typical design of carbon brush, and an electric motor. Its rotor contains a large number of coils, and so requires a more complicated commutator.



w2i

w2j

The current is a minimum when the motor is spinning fastest - why?

We will see that when a coil spins round inside a magnetic field, it generates a voltage. The faster it spins, the greater the voltage and this voltage opposes the external voltage producing the motion. Otherwise, we could switch off the external voltage, and have perpetual motion!

As a result, at full speed, the overall voltage, and so the current, is reduced.

Putting it another way, when we ask the motor to do more work, spinning against the extra friction of us pressing on the axis, it needs more current.

For your records:

- When the work done by the motor increases, the current it draws from the supply increases.
- When running freely, at maximum speed, the current is at a minimum because the rotating coil generates a voltage that opposes the externally applied voltage.

Worksheet 3

Generator principles

Introduction to motors, generators and hybrid



Electrical energy is very versatile. We use it to generate heat, light, movement and chemical reactions in the car, and store it in the car battery.

It is usually generated in a device called an alternator, an application of electromagnetic induction. To generate a voltage, you need a magnetic field, a wire conductor and relative movement between them.

In this investigation, the conductor is in the form of a coil of wire. A single wire can be used but the voltage produced is very difficult to detect.

nw3a

Over to you:

- Set up the arrangement shown in the diagram.
- The amount of electricity generated will be tiny.

We can observe it using:

- the Locktronics milliammeter module, connected as shown;
 - a multimeter, connected to points **X** and **Y**;
 - an oscilloscope, connected to points **X** and **Y**.
- If using the multimeter, set it to its most sensitive DC current scale. However, this *samples* the input signal periodically. The meter may miss an event that takes place in between samples so you may need several attempts to see convincing results.
 - For the oscilloscope, suitable settings are given at the bottom of the page.
 - Move the magnet into the coil as fast as you can. Watch what happens to the output, as you do so.
 - Next reverse the direction of motion, and pull the magnet out, watching what happens as you do so.

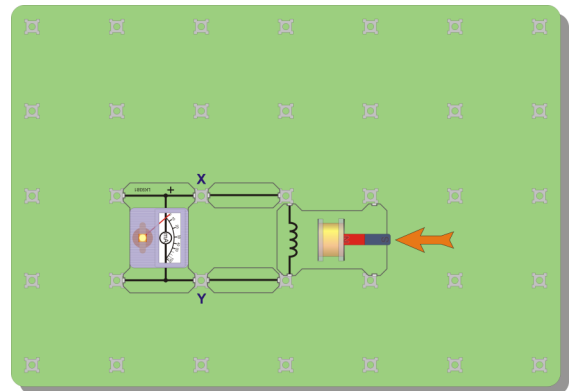

nw3b

w3c

Optional extension:

- Investigate the effect of speed of movement on the voltage produced.

Typical oscilloscope settings:

Timebase 1s/div (X multiplier x1)

Voltage range Input A ±200mV DC (Y multiplier x1)
Input B Off

Trigger mode Auto **Trigger channel** Ch.A

Trigger direction Rising **Trigger threshold** 10mV

Worksheet 3

Generator principles

Introduction to motors, generators and hybrid

So what?

From the results, the generated current and voltage have:

- a **magnitude** that depends on the speed of movement;
- a **polarity** that depends on the direction of motion.

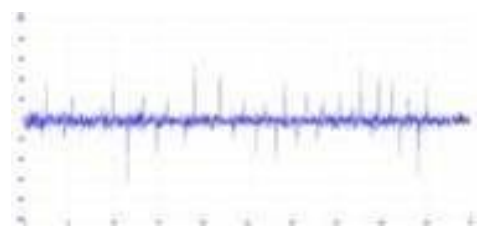

nw3c

Typical results for the oscilloscope are shown here.

Inserting the magnet generates a pulse of current in one direction, and withdrawing it produces a pulse of opposite polarity. (You may need to experiment with other time base settings.)

Here's the underlying physics:

- When the wire moves at right-angles to the magnetic field, the electrons move with it.
- Whenever electrons move, they generate a magnetic field.
- This interacts with the field of the magnet, exerting a force on the electrons at right-angles to the direction of motion and to the magnetic field.
- This force pushes electrons along the wire, generating a voltage and a current if there is an electrical circuit.
- Using a coil of wire increases the size of voltage and current generated because each wire turn in it is moving inside the magnetic field, and so has electricity generated in it.

The effects of all the turns add together, increasing the amount of electricity generated.

Fleming's Right-hand 'dynamo' rule:

Fleming devised a painful way of predicting the direction of the generated current .

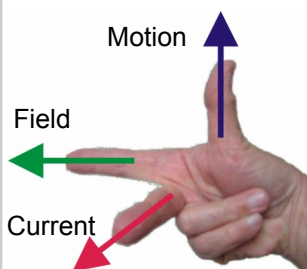

Use your **right**-hand to produce the gesture shown in the picture.

Fore finger, centre finger and thumb are all at right-angles to each other!

When the **F**ore finger points in the direction of the magnetic **F**ield (from North pole to South pole,) and the **th**umb points in the direction of the **M**otion, the **C**entre finger points in the direction of the resulting **C**urrent.

This is also known as the *dynamo rule*.

nw3d

Optional extension:

If you have other coils available, and other magnets, you could show that the magnitude also depends on the number of turns of wire in the coil and the strength of the magnetic field.

For your records:

Copy and complete the following:

- The size of the voltage and current generated depend on the and the, and their direction that depends on

Fleming's dynamo rule:

- Using the hand, hold the thumb, fore finger and centre finger at to each other.
- Keeping this shape, move the hand until the fore finger points in the direction of the, (from to) and the thumb points in the direction of
- The centre finger now points in the direction of

Worksheet 4

Hybrid principles

Introduction to motors, generators and hybrid



A car, travelling at the speed limit, has around 140 000J of kinetic energy, enough to boil a typical kettle full of water. When the car is braked to a standstill, a conventional car loses all that energy as heat in the brakes. What a waste!

The obvious answer is to store that energy and use it later to accelerate the car, but that's not easy.

One way to do this is to convert it into electrical energy, store it, and use it later when the car moves off. It can be stored in batteries, and in components called capacitors, shown in the picture opposite.



Over to you:

1. Store it:

- Set up the arrangement shown opposite.
- Turn the handle of the hand-cranked generator first anticlockwise and then clockwise.

Notice that some effort is needed to turn the handle, and that the voltmeter shows a reading only when you turn the handle clockwise.

- Now turn the handle clockwise for around one minute, and then pause. Notice that the capacitor charges up, and stays charged when you stop. (If you look closely at the voltmeter, you will see the voltmeter pointer move slowly back towards zero volts. This kind of capacitor slowly loses its charge.)
- Press the push switch before the voltmeter reading falls to zero. Notice the effect on the generator, and the voltmeter.

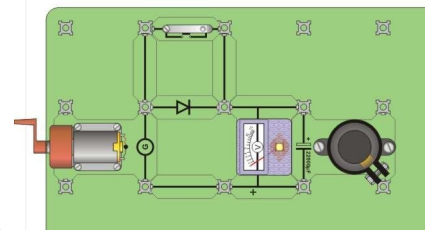

2. Use it:

- Now build the circuit shown in the second diagram.
- Turn the handle on the hand-cranked generator clockwise, fast enough to light the bulb. Remember how fast you have to turn the handle!
- Now build the circuit shown in the third diagram.
- With the push switch open (off), turn the handle clockwise at the same rate as in the previous circuit until the voltmeter shows that the capacitor is charged to around 10V.
- Stop winding, and instead press the push switch. Notice the effect on the bulb and on the voltmeter.

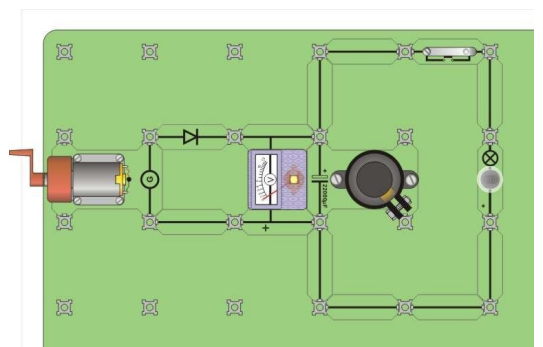
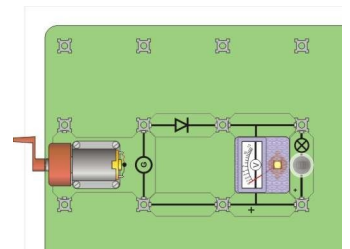

Worksheet 4

Hybrid principles

Introduction to motors, generators and hybrid

So what?

What is a capacitor?

- It consists of three sheets, (**A**, **B** and **C** in the diagram.)
- Plates **A** and **C**, are metal, usually aluminium.
- Sheet **B** is an insulator, which stops **A** and **C** touching.
- The three are usually rolled up into a 'Swiss roll', with wires connected to each metal plate, (middle diagram.)
- It is then covered in a protective casing, (bottom diagram.)

Normally, the metal sheets are uncharged. An electric current charges one plate positively, and the other negatively.

This storage of charge is how the capacitor stores energy.

Using capacitors to store energy presents two problems:

- they are practical for storing only small amounts of energy;
- they 'leak' charge, and so can store energy for a limited time only .

Part 1: The hand-cranked generator represents the braking system. It requires effort and energy to turn the generator handle. Some of that energy is stored in the capacitor. Applying the brakes, makes the generator rotate, and some of the vehicle's kinetic energy is stored as electrical energy. Slowly, the capacitor loses its charge, and stored energy, though modern capacitors can be really good at retaining charge for long periods.

Press the push switch, and the generator becomes an electric motor. This is very handy - it means that the same device can be used as both a generator and a motor in a hybrid vehicle.

Part 2: shows that this process is not totally energy efficient. The second circuit has the generator connected directly to the bulb. In the third, it charges the capacitor, and then that is connected to the bulb.

Much more light is produced in the second circuit than in the third for a similar energy input from the generator. Nevertheless, it is much better than the conventional braking system where all the kinetic energy is wasted as heat.

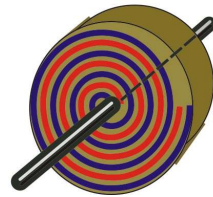
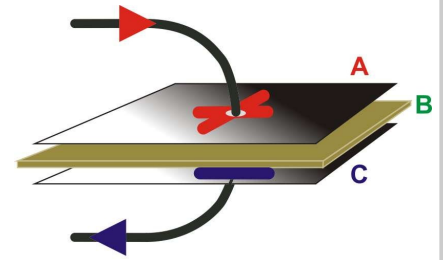

nw4f

nw4g

For your records:

- Answer questions 1 to 3 with clear explanations, but keep them as short as possible.
1. Why was the diode used in the three circuits?
 2. How is energy stored in a capacitor?
 3. In what way is a battery different from a charged capacitor?
- Use the internet to find out as much as you can about ultracapacitors, Present your results to the rest of the class in the form of a display.

Worksheet 5

Generating electricity - a closer look

Introduction to motors, generators and hybrid



Worksheet 3 focussed on the physics of electricity generation. This one looks at how to generate more electricity and at an important application.

In vehicle technology, the electrical system obtains energy from a combination of the battery and the alternator. The output of the alternator is rectified and regulated, and used to deliver electrical energy to peripheral units, like head-lamps, and to keep the lead-acid battery charged.

Elsewhere, eddy current braking uses these same principles to slow down vehicles without relying on friction braking.

nw5a

Over to you (optional investigations):

1. Generating more electricity:

This investigation looks at the electricity generated when a magnet is dropped through a coil, mounted on a plastic tube. The electricity generated depends on factors like the number of turns of wire, and the speed of motion of the magnet.

- Connect the Faraday's law apparatus, shown opposite, to an oscilloscope., to monitor any electricity generation. (Typical settings are given below.)
- Drop the magnet through the coil, and record the result on the oscilloscope.
- Reverse the magnet and do the same thing again.

(Optional extension:)

- Investigate the connection between the speed of movement and the amount of electricity produced using this kit. This requires that you can vary the speed, and measure it!

2. Eddy current magic:

The Lenz's law kit consists of a copper tube and two identical-looking projectiles.

- Hold the copper tube in a vertical position.
- Drop the first projectile down the tube.
- Now drop the second projectile. What is the difference?
- Look at the two projectiles. One is a magnet, the other is not. Find out which is which - you might need an object like a paper clip to help you decide.
- Which fell faster? Why?

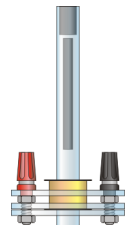

nw5b



nw5c

Typical oscilloscope settings:

Timebase 1s/div (X multiplier x1)

Voltage range Input A $\pm 500\text{mV DC}$ (Y multiplier x1)
Input B Off

Trigger mode Auto **Trigger channel** Ch.A

Trigger direction Rising **Trigger threshold** 10mV

Worksheet 5

Generating electricity - a closer look

Introduction to motors, generators and hybrid

So what?

A typical trace for the first investigation is shown opposite.

The spikes are produced by pulses of current generated when the magnet falls through the coil.

The bipolar nature of the pulses (above and below the centre axis,) is the result of the magnet first approaching and then retreating from the coil, generating a current first in one direction and then in the other.

This is a demonstration of Faraday's law of electromagnetic induction.

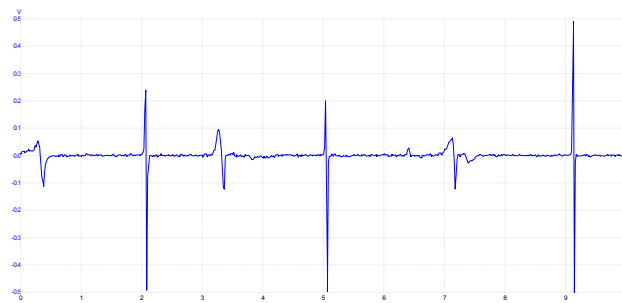

nw5d

Eddy current magic -

The unmagnetised projectile did exactly what was expected - it fell under gravity.

The magnet fell much more slowly. Its moving magnetic field interacted with the conductor, the copper pipe, and random currents were generated as a result. These produced a magnetic field that opposed the motion, slowing it down, just as Lenz's law predicts.

This effect is used in braking systems, for some buses and trains. A disc attached to the rotating wheels of the vehicle sits in between the poles of an electromagnet.

Normally, there is no effect on the spinning disc.

However, when the electromagnet is energised, the resulting magnetic field induces eddy currents in the spinning disc. In turn, these produce a magnetic field that opposes the motion, slowing down the disc and converting its rotational energy to heat.

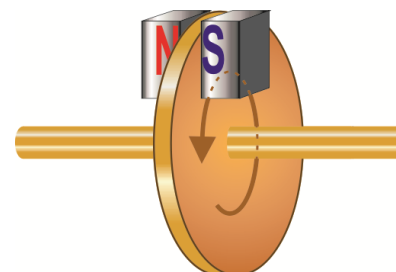

nw5e

The braking effect is varied by adjusting the current to the electromagnet. As the spinning disc slows, the induced eddy currents decrease, reducing the braking effect. In this way, the vehicle is braked smoothly.

For your records:

- Write an account, in less than fifty words, to **explain** to a colleague what happened in the Lenz's law demonstration.
- Use the internet to find out as much as you can about:
 - applications of Faraday's law of electromagnetic induction, (such as induction heaters;)
 - applications of Lenz's law (such as magnetic levitation for transport.)
- Present your results to the rest of the class in the form of a display.

Worksheet 6

Transformers

Introduction to motors, generators and hybrid



A huge advantage of generating electricity as AC is that it allows the use of transformers, to step-up or step-down an AC voltage to any desired value.

Our treatment of the transformer links it, in four steps, to the principles we met earlier, where we saw that an electric current is generated when a magnetic field moves across a conductor.

In the transformer, the moving magnetic field is produced by an electromagnet supplied with AC.

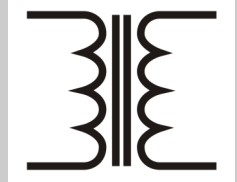

Over to you:

Step 1 - Moving the magnet:

- Build the arrangement shown opposite.
- Suitable oscilloscope settings are given below.
- Plunge a magnet into the coil, and then pull it out, watching the oscilloscope as you do so.

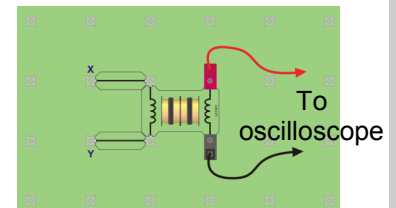

Step 2 - Electromagnet, not magnet:

- Now, connect the second coil, at **X** and **Y**, to a DC power supply, set to 3V.
- Switch the DC supply on and off, watching the trace as you do so.

Step 3 - AC not DC:

- Now, create a moving magnetic field by connecting points **X** and **Y** to a signal generator, set to an amplitude of 3V and a frequency of around 1kHz.
- Switch on the signal generator, and watch the trace.

Step 4 - Intensify the field:

- Slide a ferrite core down the middle of the two coils, and notice the effect this has.
- We now have a simple but very inefficient transformer!

Optional extension:

Investigate the effect of:

- changing the amplitude of the AC supply from the signal generator;
- changing the frequency of the AC supply from the signal generator;
- linking the coils with cores made from other materials, like steel, instead of ferrite.

Worksheet 6

Transformers

Introduction to motors, generators and hybrid

So what?

The pictures show typical traces for this investigation:

- the upper one shows current spikes generated when the DC supply to the second coil is switched on and off.
- the lower one shows current generated when the second coil is connected to the AC supply .

We saw earlier that the essential ingredients to generate electricity are a magnet, wire and movement. Here, we have replaced the magnet with an electromagnet (second coil), and produced movement by using an alternating magnetic field.

One coil, called the **primary**, is supplied with AC current, and generates an alternating magnetic field. This links with the other coil, called the **secondary**. As a result, an alternating voltage is generated in the secondary. This is the principle of the transformer.

Some refinements:

- The *strength* of the magnetic field in the primary depends on factors like:
 - the number of turns of wire in the primary coil
 - the current flowing through it, which, in turn, depends on the voltage applied to it.
- The *voltage* generated in the secondary coil depends on factors like:
 - the strength of the magnetic field generated by the primary
 - the number of turns of wire in the secondary coil
 - how effectively the magnetic field of the primary links with it.

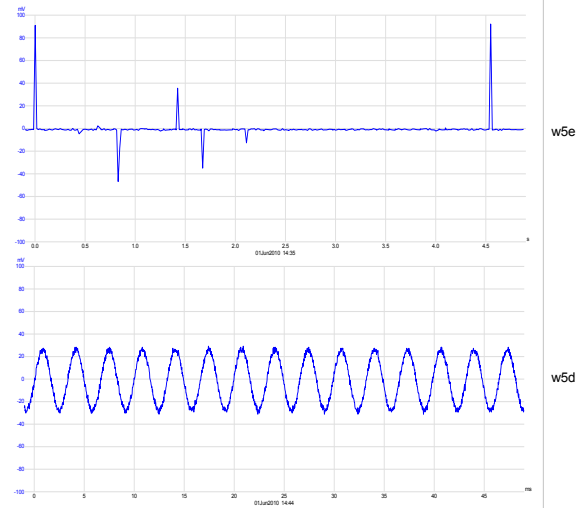

For your records:

- Copy the circuit symbol for the transformer, given at the top of the previous page.
- Describe the role played by each of the three components in the transformer:
 - the primary coil,
 - the secondary coil,
 - the core.

Worksheet 7

Practical transformers

Introduction to motors, generators and hybrid



Transformers play an important role in many electrical and electronic applications by allowing AC voltages to be stepped up or down, efficiently, to any desired value.

Here, you investigate a small transformer used in step-down and then step-up mode.

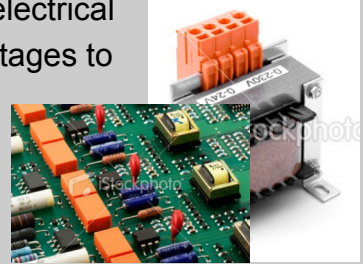

Over to you:

Step-down transformer:

In a step-down transformer, the primary coil, the one supplied with AC power, has more turns of wire than the secondary, the one that generates the transformer output voltage.

Here we use a commercial transformer with a turns ratio of 2:1, meaning that one coil has twice as many turns as the other. The primary will be the '2' coil, and the secondary the '1' coil. It has a laminated magnetic core, meaning that is made by 'gluing' together a lot of sheets (= lamina in latin) of magnetic material.

- Build the system shown, which delivers power to a 1kΩ load.
- Connect a signal generator to the '2' coil (primary). Use the low impedance output (typically 50Ω.) Set it to output a sine wave with frequency of 1kHz, and amplitude 6.0V. (If in doubt, check these with your instructor.)
- Connect a digital multimeter, set on the 20V AC voltage range, to measure voltage V_P across the primary (the '2') coil, and then V_S across the secondary (the '1' coil.)
- Set the multimeter to the 20mA AC current range, and connect it to replace the link below the '2' coil, to read the primary current, I_P .
- Replace the connecting link.
- In the same way, measure the current, I_S , in the secondary coil.
- Record all measurements in a table, like that shown opposite.

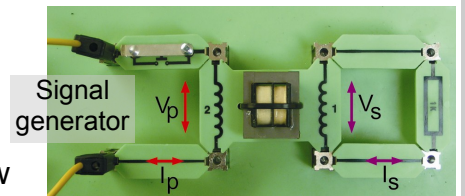

Reading	Step-down	Step-up
V_P		
V_S		
I_P		
I_S		

Step-up transformer:

In a step-up transformer, the primary coil has fewer turns than the secondary. In this case, the primary will be the '1' coil, and the secondary the '2' coil.

- The system is the same as above, except that the transformer carrier is now upside down.
- Connect the multimeter to measure the secondary voltage V_S . Adjust the amplitude of the signal from the signal generator until V_S is the same as in the previous investigation.
- Now measure and record V_P , I_P and I_S .

Worksheet 7

Practical transformers

Introduction to motors, generators and hybrid

So what?

The last worksheet looked at transformer principles, but the final device was very inefficient. This is an improved version - two coils, side by side, as before, but linked by a much more elaborate core, threading through the centre of the coils, and wrapped around the outside too. The result - more effective linkage between the magnetic field generated in the primary and the secondary coil.

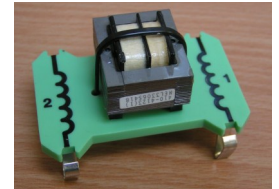

What the results show:

- Look at the ratio $V_P:V_S$ for both step-up and step-down transformers. The transformer equation says that, for an ideal transformer:

$$V_P / V_S = N_P / N_S$$

where N_P and N_S are the number of turns on the two coils.

- Next look at the ratio $I_P:I_S$ for both transformers.

In general terms:

- a step-up transformer 'steps up' the voltage (virtually doubles it) but 'steps down' the current - I_P is much greater than I_S .
- a step-down transformer 'steps down' the voltage, but delivers the same secondary current for a much smaller primary current.
- Both delivered the same voltage, V_S , to the $1k\Omega$ load, and so I_S , the secondary current, was very similar in both cases.

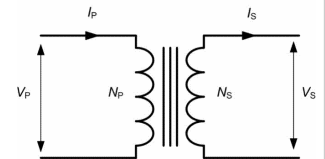
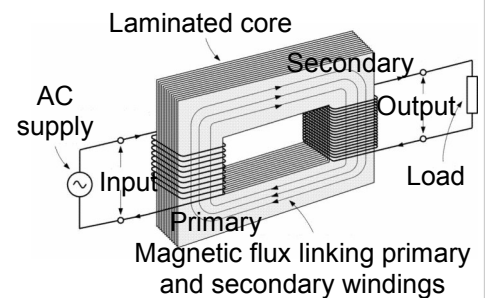

The acid test:

What about the power? Was it stepped up or stepped down?

Using the formula:

Power = Current x Voltage:

Power delivered to the primary coil,

$$P_P = I_P \times V_P = \dots\dots\dots \text{mW}$$

Power delivered from the secondary,

$$P_S = I_S \times V_S = \dots\dots\dots \text{mW}$$

For an ideal transformer (100% efficient):

$$P_P = P_S$$

$$\text{and } I_S / I_P = N_P / N_S$$

Optional extension:

Investigate the effect of applied frequency on the output of the transformer. Research the topic of power matching to explain your results.

For your records:

- Copy the transformer relation, and explain what it means, in words.
- Explain what is meant by the terms *step-up* and *step-down* when applied to transformers. Be clear about the role of the number of turns of wire, and about exactly what is stepped up, and what is stepped down in each case.

Worksheet 8

Half-wave rectifier

Introduction to motors, generators and hybrid



Most of the auto electrical system runs on DC (direct current.) The alternator, however, generates AC.

We need to turn AC into DC so that the alternator can service the needs of the system. This process is called rectification, and the device used is the diode.

There are several ways in which diodes can be used as rectifiers. This worksheet looks at the simplest - the half-wave rectifier.

Over to you:

- Set up the circuit shown in the top diagram, using the AC power supply. The $1k\Omega$ resistor represents all the devices in the auto electrical system.
- There are two positions for the oscilloscope - connected to AC or connected to DC.
- If your oscilloscope has two input channels, then connect one to AC, and the other to DC.
- If your oscilloscope has only one input channel, then connect it to measure each of the signals in turn. The settings for the oscilloscope are given at the bottom of the page, (identical for both methods.) Record the trace seen on the screen both before and after the diode.
- You should find that the current through the $1k\Omega$ resistor is DC - it does not change direction. However, it is not smooth DC.
- The performance of this rectifier can be improved by adding a capacitor. Set up the circuit shown in the second diagram, where a large value capacitor, ($2200\mu\text{F}$), known as a smoothing capacitor, has been added.
- Using the same settings as before, use an oscilloscope to record the waveform across the $1k\Omega$ load (by connecting to the points labelled DC again.)

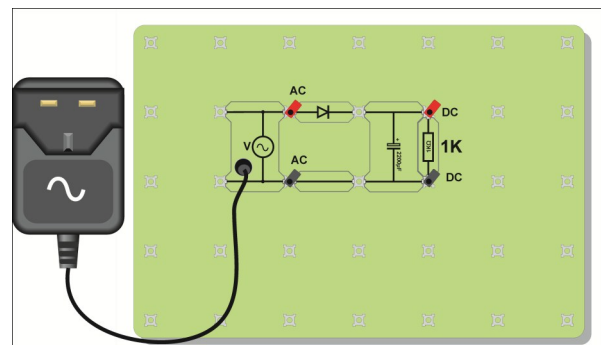
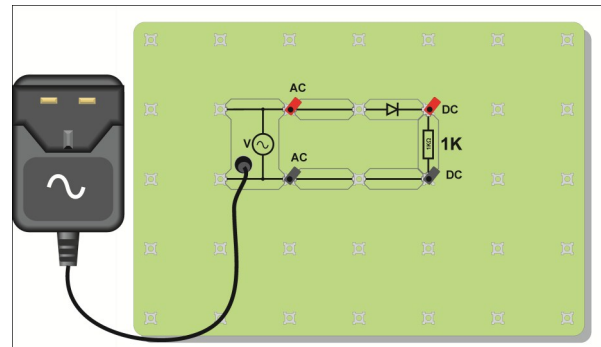

Typical oscilloscope settings:

Timebase	10ms/div (X multiplier x1)		
Voltage range	Input A $\pm 10\text{V DC}$ (Y multiplier x1)		
	Input B same setting if used		
Trigger mode	Auto	Trigger channel	Ch.A
Trigger direction	Rising	Trigger threshold	200mV

Worksheet 8

Half-wave rectifier

Introduction to motors, generators and hybrid

So what?

The diode allows current to flow through it, and the $1k\Omega$ load, in one direction only. It acts as a small resistor for currents trying to flow in one direction (when forward-biased,) and as a very large resistor for currents trying to flow in the other direction, (when reverse-biased.)

The top picture shows a typical trace obtained from the first circuit. The AC input is turned into DC (rectified.) Notice that while the output is DC (as it never crosses the 0V line,) it is not steady DC. The second picture shows the same signal, using a different time base setting for the oscilloscope (2ms/div.)

This shows the rectification in more detail. In particular, notice that the DC output, in red, is approximately 0.7V lower than the AC input. The diode does not really conduct until the voltage across it reaches 0.7V. Once it starts to conduct, there is a 0.7V drop across the diode, leaving the DC output 0.7V below the AC input at all points.

The third picture shows the effect of adding a smoothing capacitor. The output voltage is now both DC and steady. There are issues about the size of the capacitor. These will be explored later.

Simple rectification

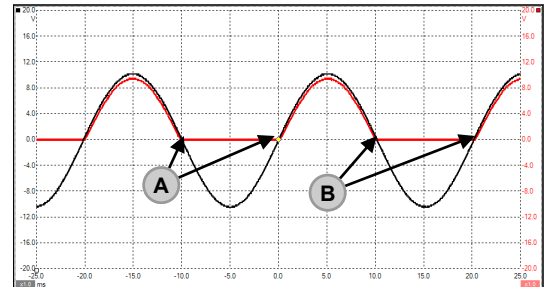

AC — A - AC current changes direction here
DC — B - DC current does not change direction

A closer view

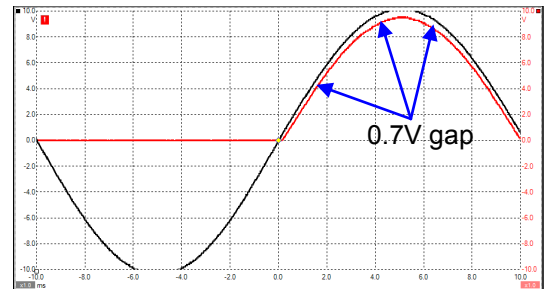

Using a smoothing capacitor

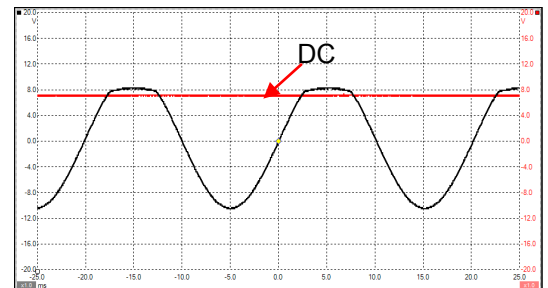

For your records:

- The process of turning AC into DC is called rectification.
- Half-wave rectification uses only one diode, but results in only half of the AC signal being turned into DC. No current at all flows for half of the time.
- The silicon diode conducts only when it is forward-biased, and there is a voltage of at least 0.7V across it.
- The output of this half-wave rectifier is 0.7V less than the AC input, and is not smooth DC.
- A large capacitor can be connected across the output of the half-wave rectifier to smooth the DC signal produced.

Worksheet 9

Full-wave rectifier

Introduction to motors, generators and hybrid



A half-wave rectifier circuit uses only one diode, but it does not make efficient use of the electrical energy on offer. For half of the time, no current at all flows through the load.

A full-wave rectifier overcomes this limitation, but uses a number of diodes to do so, and drops more of the AC voltage across them as a result. Nevertheless, it is the common solution to converting the AC output of the alternator to DC.

Over to you:

- Set up the circuit shown in the diagram, using the AC power supply. Once again, the $1k\Omega$ resistor represents the load - all the devices in the auto electrical system.

Important:

If your oscilloscope has two input channels, DO NOT connect one to AC, and the other to DC. This will short-circuit one of the diodes.
(The reason is given on the next page.)

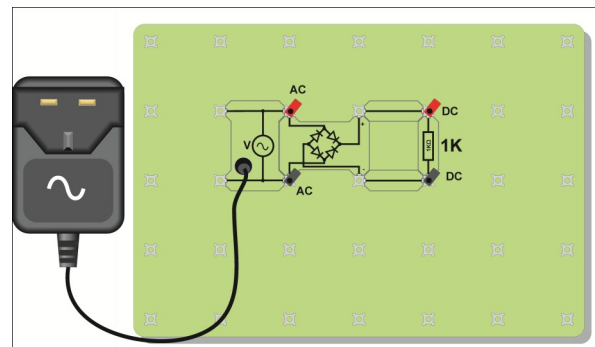

w8m

- Use only one channel of your oscilloscope. First, connect it to measure the AC signal input. Then connect it to measure the DC signal output. Oscilloscope settings are given below.
- Record both the AC and DC traces.
- The DC output varies less than that for half-wave rectification, but it is still not a steady voltage. Connect a large capacitor across the output of the full-wave rectifier. This is shown opposite.
- With the same settings as before, use the oscilloscope to record the output waveform.

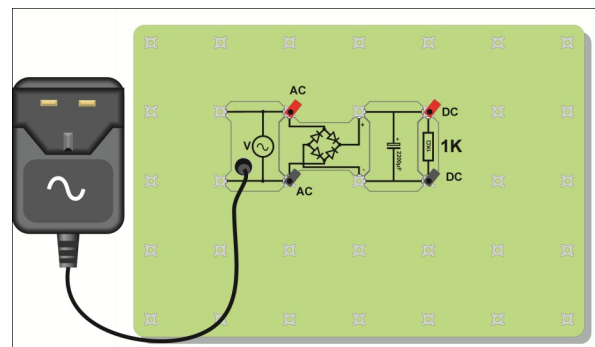

w8n

Typical oscilloscope settings:

Timebase	10ms/div (X multiplier x1)		
Voltage range	Input A $\pm 10V$ DC (Y multiplier x1)		
	Input B Off		
Trigger mode	Auto	Trigger channel	Ch.A
Trigger direction	Rising	Trigger threshold	200mV

Worksheet 9

Full-wave rectifier

Introduction to motors, generators and hybrid

So what?

The circuit diagram for the full-wave rectifier is shown opposite.

It was pointed out earlier that, in this circuit, you cannot measure AC and DC simultaneously using two oscilloscope channels.

That would require connecting one channel to points **A** and **C**, for the AC signal, and the other to points **B** and **D** to measure DC.

However, oscilloscopes have a common 0V connection between the two channels. This means that you would be connecting together points **C** and **D**, say, through the common oscilloscope connection, short-circuiting one of the diodes.

The three traces show the AC signal going into the full-wave rectifier, the DC output, and the effect of adding a capacitor to smooth the output.

The DC output, in the middle trace, is an improvement on the half-wave output, in that current flows through the load throughout the AC cycle.

Again, this is DC current, because the trace never crosses the 0V line. However, once again, a smoothing capacitor is needed to provide steady DC.

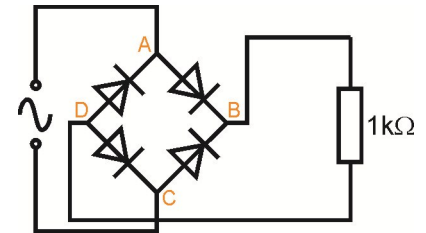

Full wave rectification

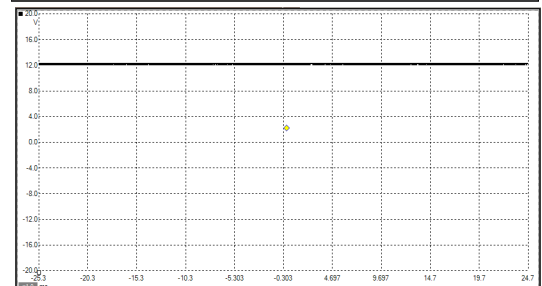
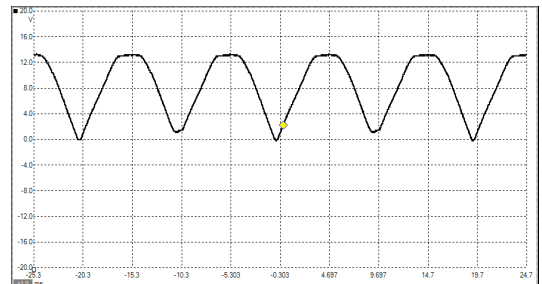
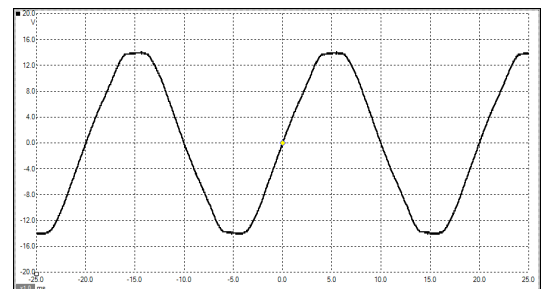

For your records:

- Full-wave rectification uses at least four diodes, but allows current to flow through the load throughout the AC supply cycle.
- The output of this full-wave rectifier, using four diodes, is 1.4V less than the AC input, and is not smooth DC.
- Again, a large capacitor can be connected across the output of the rectifier to smooth the DC signal produced.

Worksheet 10

The zener diode

Introduction to motors, generators and hybrid

It is a diode, so it conducts in one direction only, when forward biased. It is used, however, connected in reverse bias, in what is known as zener breakdown, to control the voltage sent out to a circuit. It is a voltage regulator.

This worksheet investigates its behaviour, first in forward bias and then in reverse bias..

The zener diode

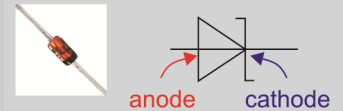

w9a

Over to you:

1. Forward bias:

- Set up the circuit shown opposite. The anode of the zener diode is connected closer to the positive end of the power supply than to the negative. It is **forward biased**.
- The power supply is set to 6V DC. A 1k Ω resistor is connected in series with the zener diode.
- Connect a multimeter, set to the 2V DC range, to read the voltage V_Z across the zener diode.
- Remove the connector between the 'pot' and the 1k Ω resistor, and replace it with a second multimeter, set to the 20mA range, to read the zener current I_Z .
- The 'pot' allows us to vary the voltage applied to the zener diode.
- Turn the knob on the 'pot' fully anticlockwise, to set the supply voltage to zero.
- Turn the knob slowly clockwise until the current through the diode reaches 0.2mA. Then read the voltage across the diode.
- Copy the table and use it to record your results.
- Keep increasing the current in 0.2mA steps, up to 2.0mA, taking the voltage reading each time.

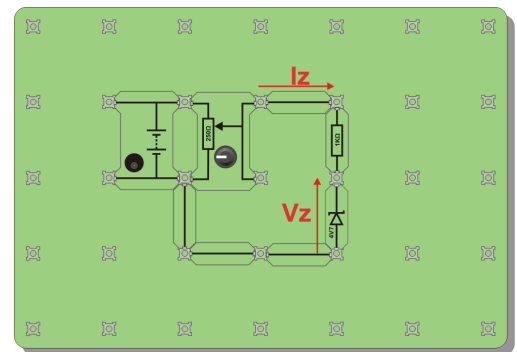

w9b

I_Z in mA	V_Z in V
0.2	
0.4	
0.6	
0.8	
1.0	
1.2	
1.4	
1.6	
1.8	
2.0	

2. Reverse bias:

- Change the power supply setting to 9V DC.
- Swap the 1k Ω resistor for a 270 Ω resistor.
- Reverse the direction of the zener diode, so that it is reverse biased.
- Repeat the procedure outlined above, increasing the current through the zener in 0.2mA steps, up to 5.0mA, measuring the voltage across it each time.
- Record your results in a second table, like the first.

Worksheet 10

The zener diode

Introduction to motors, generators and hybrid

So what?

- Plot a graph of your results for the behaviour of the zener diode, with current on the vertical axis, and voltage on the horizontal.
- Draw a smooth curve through the experimental points. The result should look like the graph shown opposite.
- The results show that once the zener breakdown voltage is reached, the voltage across the zener diode hardly changes as the current increases. This is ideal behaviour for a power source.

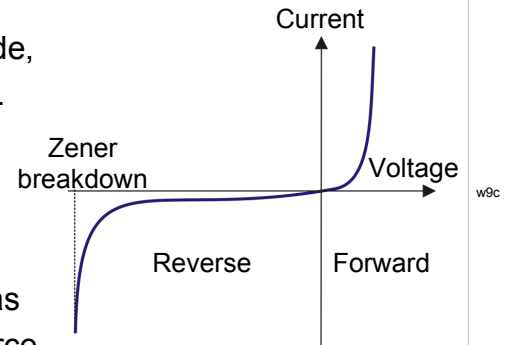

A zener voltage regulator:

The ideal voltage regulator offers a steady output voltage no matter what changes occur in either the output current or in the supply voltage. We have seen that a zener diode comes close to this behaviour. The circuit diagram shows a simple zener voltage regulator.

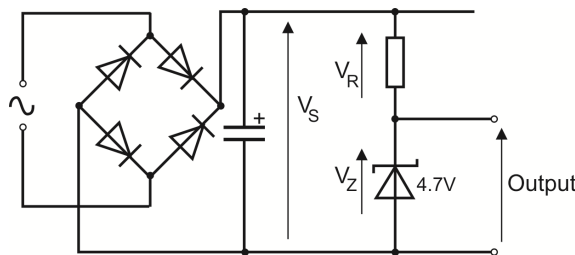

As the supply voltage V_S changes, the voltage V_Z across the zener stays steady, and the voltage V_R across the resistor changes.

For example, when $V_S = 8.5\text{V}$, $V_Z = 4.7\text{V}$ and so $V_R = 3.8\text{V}$ ($= 8.5 - 4.7$).

If V_S then rises to 8.8V , $V_Z = 4.7\text{V}$ and $V_R = 4.1\text{V}$ ($= 8.8 - 4.7$).

When the current drawn by the output changes, the voltage across the zener remains steady, as the graph at the top of the page shows.

Optional extension:

- Build the circuit shown above.
- Connect different resistors as loads to the output, and measure the output voltage for each.

For your records:

- Copy the diagram given at the top of the previous page showing the circuit symbol for a zener diode and labels to identify the anode and cathode.
- Copy the graph given above showing the I/V behaviour of a zener diode.
- Draw the circuit diagram for a voltage regulator based on a zener diode.
- Explain why the output remains steady:
 - when the supply voltage changes;
 - when the output current changes.

Instructor Guide

Introduction to motors, generators and hybrid

About this course

Introduction

The course is essentially a practical one. Locktronics equipment makes it simple and quick to construct and investigate electrical circuits. The end result can look exactly like the circuit diagram, thanks to the symbols printed on each component carrier.

Aim

The course introduces students to the principles of motors and generators, in an automotive context, through a series of practical experiments which allow students to unify theoretical work with practical

Prior Knowledge

It is recommended that students have followed the 'Electricity Matters 1' and 'Electricity Matters 2' courses, or have equivalent knowledge and experience of building simple circuits, and using multimeters.

Learning Objectives

On successful completion of this course the student will be able to:

- identify five uses of electric motors in a car;
- recall that the force acting on a current-carrying wire acts at right-angles to the current and to the magnetic field;
- recall Fleming's left-hand rule;
- explain the need to reverse the current in the rotor of an electric motor;
- name commutators and slip-rings, used with AC, as two ways of reversing the current in a rotor;
- relate the current drawn from a power source to the work done by a rotating electric motor;
- identify the alternator as the means of generating electricity in automotive equipment;
- state that current induced in a wire moving in a magnetic field flows at right angles to the motion and to the field;
- relate the size of current induced to the speed of movement, strength of field and number of conductors present;
- explain the shape of a voltage / time graph showing voltage induced in a wire moving in a magnetic field;
- state that an electrical generator can also act as a motor;
- describe how a braking system can conserve energy by storing it in a capacitor system;
- describe the general structure of capacitors and ultracapacitors;
- explain how the production of eddy currents can be harnessed to produce a braking effect;
- describe the use of commutators and slip-rings to extract electrical energy from a generator;
- draw the circuit symbol for, and describe the general features of a transformer;
- relate these features to the principles behind electricity generation;
- distinguish between the behaviour of step-up and step-down transformers;
- define and use the transformer relation;
- explain the relationship between current and voltage in the primary coil and secondary coils of a transformer;
- recall that practical transformers waste energy;
- calculate the power delivered to the primary and available from the secondary of a transformer;
- define rectification as the process of turning AC into DC;
- state that half-wave rectification uses only one diode, but produces a DC current for only half of the time;
- recall that half-wave rectification produces a DC output voltage which is $\sim 0.7V$ less than the peak AC voltage;
- state that full-wave rectification uses at least four diodes, but produces a DC current throughout the AC cycle;
- recall that full-wave rectification produces a DC output voltage which is $\sim 1.4V$ less than the peak AC voltage;
- draw the circuit symbol for a zener diode, and identify the anode and cathode;
- sketch and describe the implications of the I/V characteristic of a zener diode;
- describe the features of a zener diode that make it useful as a voltage regulator;
- explain how the output of a zener-based voltage regulator resists changes in input voltage and in output current.

Instructor Guide

Introduction to motors, generators and hybrid

What the student will need:

To complete the Motors and Generators course, the student will need the parts shown in the table on the right, all of which is included in our Locktronics solution LK7445.

In addition the student will need:

- One function generator, capable of generating sinusoidal AC signals with frequencies up to 10kHz. For this we recommend part HP8990.
- One oscilloscope with two traces. You have a choice here between a conventional oscilloscope and a PC based oscilloscope. For the former, we recommend part LK4679 which is a conventional oscilloscope. For the latter, we recommend the HP4679 Picoscope which is a 5MHz dual trace PC based scope.
- Two multimeters, capable of measuring AC currents in the range 0 to 20mA, and AC voltages in the range 0 to 15V. We recommend our multimeter LK1110.

Qty	Code	Description
1	LK8900	7 × 5 locktronics baseboard
8	LK5250	Connecting link
1	LK6482	Fleming's motor rule apparatus
1	LK7487	Lenz's law kit
1	LK7489	Faraday's law kit
1	LK7485	Alnico rod magnet
1	LK9998	400 turn coil carrier
1	LK7483	1:1 transformer with retractable core
1	LK4123	Transformer, 2:1 turns ratio
1	LK6706	Motor, 3-12V dc, 0.7A
1	LK4893	Hand cranked generator
1	LK3662	Capacitor, 22,000uF, electrolytic
1	LK6203	Capacitor, 2,200uF, electrolytic
1	LK5202	Resistor, 1k, 1/4W, 5%
1	LK5205	Resistor, 270ohm, 1/4W, 5%
1	LK5208	Potentiometer, 250 ohm
1	LK5243	Diode, power, 1A, 50V
1	LK5247	Zener diode, 4.7V
1	LK5266	Bridge rectifier
1	LK3982	Voltmeter, 0V to 15V
1	LK8397	Ammeter, 0A to 1A
1	LK9381	Ammeter, 0mA to 100mA
1	LK6207	Switch, push to make
1	LK2340	AC voltage source carrier
1	LK8275	Power supply carrier with battery symbol
1	LK5570	Pair of leads, red and black, 4mm to croc clips
1	LK5603	Lead, red, 500mm, 4mm to 4mm plug
1	LK5604	Lead, black, 500mm, 4mm to 4mm plug
1	HP5529	BNC male to dual 4mm sockets adapter

Power sources:

The investigations in this module require two power sources, one AC and the other DC. Both of these are available as 'plug-top' power supplies.

The HP2666 is an adjustable DC power supply offering output voltages of either 3V, 4.5V, 6V, 7.5V, 9V or 12V, with currents typically up to 1A. Also included are adaptors to fit the majority of international main electricity outlets

The voltage is changed by turning the selector dial just above the earth pin until the arrow points to the required voltage. (The instructor may decide to make any adjustment necessary to the power supply voltage, or may allow students to make those changes.)

There are three versions of our 12V AC supply available to suit the mains outlets of different countries

HP3728	12V AC supply, UK connector
HP4429	12V AC supply, Euro connector
HP4699	12V AC supply, USA connector

Instructor Guide

Introduction to motors, generators and hybrid

Using this course:

It is expected that the series of experiments given in this course is integrated with teaching or small group tutorials which introduce the theory behind the practical work, and reinforce it with written examples, assignments and calculations.

The worksheets should be printed / photocopied / laminated, preferably in colour, for the students' use. Students should be encouraged to make their own notes, and copy the results tables and sections marked 'For your records' for themselves. They are unlikely to need their own permanent copy of each worksheet.

Each worksheet has:

- an introduction to the topic under investigation;
- step-by-step instructions for the investigation that follows;
- a section headed 'So What', which aims to collate and summarise the results, and offer some extension work. It aims to encourage development of ideas, through collaboration with partners and with the instructor.
- a section headed 'For your records', which can be copied and completed in students' exercise books.

This format encourages self-study, with students working at a rate that suits their ability. It is for the instructor to monitor that students' understanding is keeping pace with progress through the worksheets. One way to do this is to 'sign off' each worksheet, as a student completes it, and in the process have a brief chat with the student to assess grasp of the ideas involved in the exercises it contains.

Time:

It will take students between seven and nine hours to complete the worksheets.

It is expected that a similar length of time will be needed to support the learning that takes place as a result.

Instructor Guide

Scheme of Work

Introduction to motors, generators and hybrid

Worksheet	Notes for the Instructor	Timing
1	<p>Motors abound in automotive systems, and come in a variety of shapes and sizes. It is helpful to have a display of examples to introduce this topic.</p> <p>The experiment itself lasts only a few minutes, but the students should be allowed to 'play' with the kit until they are confident about what is happening. The instructions tell them how to reverse the magnetic field, and reverse the current direction, to see what effect these changes have.</p> <p>Ultimately, the effect is pretty mysterious, and begins with the properties of electrons themselves. It depends on the previous experience of the students, and of the instructor, as to how far the explanation is taken. Electrons are 'magical' and their behaviour is beyond our everyday experience.</p> <p>For example, if an electron moves past us, we experience a magnetic field. Equally, if the electron is at rest and we move past it, the result is the same. If we move along at the same rate as an electron, we experience no magnetic field. Moving electrons are the source of all magnetic effects, even those in 'permanent' magnets, where there is no obvious flow of electrons.</p> <p>It is important that students learn to use the left-hand (motor) rule to relate the direction of the force on a conductor to the directions of current and magnetic field . They will need plenty of practice in applying this rule.</p>	20 - 30 mins
2	<p>In worksheet 1, the motion was linear. Students need plenty of time to absorb the change to rotary motion.</p> <p>The diagrams need to be studied carefully, with liberal application of the left-hand rule. Students need to realise that where the rotor is a single coil, the motion will be 'lumpy'. Maximum torque is delivered when the plane of the coil is parallel to the field, as in the first and third diagrams. When the coil is vertical, there is still a force on the two sides, but it has no turning effect. Fortunately, the momentum built up will carry the coil through that position.</p> <p>Students need to realise that rotation can continue if there is some means of reversing the current direction. In a DC motor, this can be achieved through the use of a commutator. For a simple coil, this is a drum split into halves. For multi-coil rotors, the commutator is more complicated, but does the same job.</p> <p>For AC motors, the current reverses automatically during every cycle of the AC supply. It can be delivered to the coil by two slip rings, brass rings connected one to each end of the coil.</p> <p>A common cause of difficulty is the relationship between speed of rotation and current demanded from the power source. If the motor is running at maximum speed, the only work it has to do is against frictional forces in the bearings and air resistance. As a result, it draws only a small current. When required to do additional work, the motor draws extra current to provide it with extra energy.</p>	20 - 30 mins

Instructor Guide

Scheme of Work

Introduction to motors, generators and hybrid

Worksheet	Notes for the Instructor	Timing
3	<p>The practical exercises need careful attention. The effects being studied are small and easily missed.</p> <p>If students are using digital multimeters, they should be aware that these meters sample the input signal periodically, and that short-duration pulses may be missed. Traditionally, students are always nervous about using multimeters - selecting the right range and using the correct sockets. Instructors may need to run a brief revision session beforehand, or be prepared to assist with the measurement. A further complication is that many multimeters have an internal fuse to protect against overload on DC current ranges. These 'blow' very easily, but do so out of sight, leaving the student puzzled as to the lack of activity on the meter. Instructors will need to check the meters regularly, and have a ready supply of new fuses.</p> <p>Similarly with a digital oscilloscope, the input is sampled. Repeating the action several times will help to convince the student what is going on, and may produce a good oscilloscope trace eventually.</p> <p>Fleming's right-hand (dynamo) rule will need careful explanation, and a deal of practice if students are to feel confident about its use. Some will confuse the use of the left-hand and right-hand rules.</p> <p>An explanation is given in terms of the behaviour of electrons. The instructor should judge how far to take this with a given class of students.</p>	30 - 40 mins
4	<p>In conventional road vehicles, propulsion comes from the internal combustion engine alone. A hybrid vehicle has electric motor/generators in addition. This allows the use of regenerative braking, where some of the kinetic energy of the moving vehicle is stored during braking, and used to assist acceleration later.</p> <p>This worksheet explored the principles involved. It demonstrates that an electric motor and a generator can be the same device, with its behaviour depending on the energy flow in it.</p> <p>The investigation uses a large value electrolytic capacitor, and instructors must be aware of safe practice, with regard to ensuring correct polarity and limiting use to within the working voltage of the capacitor. In this case, instructors should check that the diode is connected the right way round, that the polarity of the capacitor matches it, and that the voltmeter is connected correctly.</p> <p>The first part of the investigation demonstrates that energy can be stored in the capacitor, and also that the hand-cranked generator can also be a motor.</p> <p>The second part demonstrates that, as in all physical processes, the efficiency is less than 100%, but that the process is still worthwhile compared to conventional braking, where all energy is wasted as heat.</p> <p>The 'So what' section describes the general structure of the capacitor. The instructor may wish to elaborate on this brief description, and the following explanation of the two parts of the investigation.</p> <p>Finally, students are asked to research ultracapacitors - a rapidly developing technology with great potential for hybrid vehicles.</p>	25 - 40 mins

Instructor Guide

Scheme of Work

Introduction to motors, generators and hybrid

Worksheet	Notes for the Instructor	Timing
5	<p>The first part of this investigation is easy to deliver but may be challenging to interpret. The results of the previous worksheets should give clues as to what is happening.</p> <p>More able students can be asked to investigate the effect of speed of movement on the size of current induced.</p> <p>The second part is quick to carry out, but needs repeating a few times to be convince for students. They need to examine both projectiles closely. The task is a short one, but the explanation is not. Instructors should invite explanations on each stage of the experiment, and be prepared for detailed questions about current and resulting force direction.</p> <p>Fleming's rule should be applied, together with the <i>reductio ad absurdum</i> argument about the consequences of the force acting in the other direction.</p> <p>The practical significance of this effect includes electrical retarders for heavy vehicles like coaches and trains, and magnetic levitation. The outcome of eddy current braking is heat energy. An alternative is regenerative braking, where the energy of motion is stored in some other form - as rotational energy in a spinning flywheel, or as electrical energy in a battery.</p> <p>Students could be given the task of researching these options. For example, Formula 1 racing has dabbled with KERS (kinetic energy recovery systems.)</p>	30 - 40 mins
6	<p>Transformers can appear as mysterious objects. The aim in this worksheet is to introduce them as an extension of what has gone before. If students can accept that electricity is generated when a magnet is plunged into a coil, then they should have no difficulty with the transformer. The magnet is replaced with an electromagnet, and the motion with a moving magnetic field generated by an alternating current.</p> <p>However, use of an oscilloscope and of signal generators may cause problems and blur the sequence of events where students are not familiar with these instruments. Instructors may wish to give a short briefing about them to reduce these difficulties.</p> <p>It may not be obvious to some that switching a DC electromagnet on and off causes a moving magnetic field, and hence induces current in the secondary coil. Instructors may wish to develop understanding on this through questioning them.</p>	30 - 40 mins

Instructor Guide

Scheme of Work

Introduction to motors, generators and hybrid

Worksheet	Notes for the Instructor	Timing
7	<p>The main part of the development here is to distinguish between step-up and step-down transformers. Some students find it easy to accept 'step-down' but see 'step-up' as defying the laws of nature. It looks like something for nothing. That is why the investigation goes on to look at the effect on current, and on the overall power issues.</p> <p>The transformer used is much more efficient than the primitive device used in worksheet 5 but is far from ideal. An ideal transformer wastes no energy and so behaves the transformer relation and the relation between the current ratio and the turns ratio. The presence of cooling fins and coolant circulation in substation transformers shows that ideal transformers are difficult to design.</p> <p>The difficulties here probably centre again on the use of signal generators and digital multimeters. The choice of 300Hz for the signal frequency is purely pragmatic - it produces more efficient transforming. Faster students might be given the task of investigating the effect of frequency. In automotive alternators, the situation is made more complicated by the use of multi-phase alternators anyway. Not everything is simply 50Hz!</p> <p>The treatment of the results introduces the transformer relation, which works pretty well, and the issue of stepping up and stepping down current, which is more problematic. Students should be asked to compare the use of a transformer to reduce voltage, with the use of a series resistor to drop some of the voltage. The transformer wins every time!</p>	25 - 40 mins
8	<p>This worksheet introduces the process of converting AC to DC, called rectification. There are several ways to implement rectification. We look at two, known as half-wave and full-wave rectification. Full-wave rectification is the subject of worksheet 8. Here we look at half-wave rectification.</p> <p>The students need reminding about the significance of voltage/time graphs. The current changes direction only when the trace crosses the 0V line. If it never crosses, then the current is DC, but not necessarily steady DC.</p> <p>Half-wave rectification uses the one-way conduction of a diode, to ensure that the current through the load never reverses i.e. is always DC. The rectifier circuit is simple - just add a diode in series with the load. However, it is not very efficient, as no current at all flows during the negative half-cycle of the AC supply. A half-wave rectifier rectifies only half of the AC 'wave'. When this is not a problem, use half-wave rectification. One such case is the simple lead-acid battery trickle charger, where it is accepted that the charging process will take some time to complete.</p> <p>The half-wave rectifier does not provide smooth DC. There is a large ripple voltage (variation in output voltage.) This can be reduced substantially by adding a high value capacitor in parallel with the load. To keep the size down, this is usually an electrolytic capacitor, and so care must be taken to ensure that it is connected the right way round, as shown in the diagram on page 14. The results also show that the output is 0.7V lower because the available voltage is shared between the conducting diode and the load.</p>	25 - 40 mins

Instructor Guide

Scheme of Work

Introduction to motors, generators and hybrid

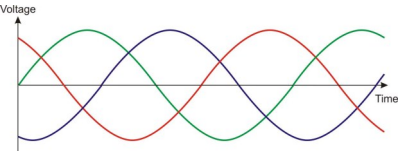
Worksheet	Notes for the Instructor	Timing
9	<p>Now the student investigates full-wave rectification. As its name suggests, it makes use of both the positive and negative half-cycles of the AC supply. A DC current can flow all the time through the load, making more efficient use of the supply.</p> <p>This improved efficiency comes at the price of more complex circuitry. At least four diodes are used to rectify the AC supply.</p> <p>Often, auto alternators output what is known as 3-phase AC, effectively three AC signals, superimposed on each other, but staggered in time. The alternator contains three independent sets of coils. The rotating electromagnet generates a separate AC signal in each set of coils. This idea is shown in the next diagram.</p>  <p>When this is the case, full-wave rectification will need six diodes.</p> <p>It is important that students do not try to use two oscilloscope input channels to capture two signals at the same time. The outer casing of the BNC connectors are usually joined together. Using two inputs, connected to different parts of a circuit, can short-circuit those parts. This is discussed in the worksheet, using a circuit diagram of the full-wave rectifier to make the issue clearer. However, instructors may wish to discuss this problem with students because of its wider implications for the use of test instruments.</p>	30 - 45 mins
10	<p>The story so far has covered generating electricity, transforming the voltage, rectifying it. All that remains is to look at controlling the delivery of the voltage. In many situations, we need a constant voltage supply. The input from the generator may change. The output demand (current) may change. The output voltage must not. This introduces the need for a voltage regulator.</p> <p>The worksheet explores the behaviour of the zener diode. Actually, all semi-conducting diodes show the same behaviour - conducting freely when forward biased, not conducting when reverse biased - well, not at first! All semiconducting diodes have a maximum reverse voltage. Beyond it, they break down and conduct. The difference with zener diodes is that they are designed to do just that, at relatively low, but carefully defined voltages.</p> <p>To start off, the students investigates the current / voltage behaviour of the zener diode. When forward biased, the result is the same as for any silicon diode - a 0.7V forward voltage drop. In reverse bias, things start off very predictably - no current. When the applied voltage approaches the zener breakdown value, 4.7V in this case, the diode starts to conduct. Very soon, it conducts freely, and the voltage drop across it changes very little as the current increases. This is just the behaviour we want for a voltage regulator.</p> <p>The next section looks at a voltage regulator circuit connected on to the back of a half-wave rectifier, and seeks to explain how it functions. In reality, it simply exploits the behaviour of the zener diode.</p>	25 - 40 mins

ni1

Using the Picoscope

Introduction to motors, generators and hybrid

The Picoscope uses the same controls as an oscilloscope:

Timebase:

- controls the scale on the time (horizontal) axis;
- spreads out the trace horizontally if a lower number is used.

Voltage sensitivity:

- controls the scale on the voltage (vertical) axis;
- spreads out the trace vertically if a lower number is used.

AC or DC:

- shows only varying voltages if AC is chosen (so centres the trace on 0V vertically;)
- shows the true voltage levels if DC is chosen.

Trigger:

- looks at the selected signal to decide when to set off on the next trace;
- waits for that signal to reach the voltage level selected before starting;
- can be either when a rising or a falling signal reaches that voltage level.

Stop / Go:

- **'Stop'** indicates that the trace is 'frozen' (i.e. showing a stored event;)
- **'Go'** shows that the trace is showing events in real-time;
- Click on the box to change from one to the other.

The settings are selected on-screen using the drop-down boxes provided.

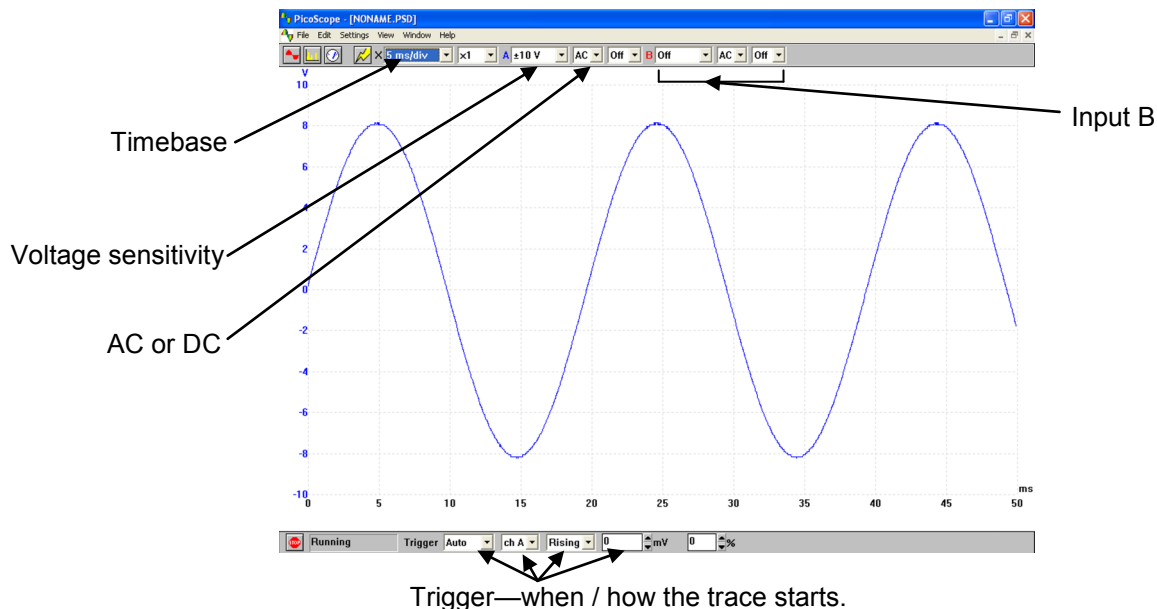

In this trace:

Timebase = 5 ms/div, so the time scale (horizontal axis) is marked off in 5 ms divisions.

Voltage sensitivity = ± 10 V, so the maximum possible voltage range (vertical axis) is +10V to -10V.

Trigger - Auto - so will show any changes in the signal as they happen;

Ch A - so looks at the signal on channel to decide when to start the trace;

Rising - so waits for a rising voltage to reach the threshold;

Threshold - 0 mV - so starts the trace when the signal on channel A rises through 0V.



pico1

PH1

Using the Picoscope

Introduction to motors, generators and hybrid

More Picoscope traces *for the same signal*:

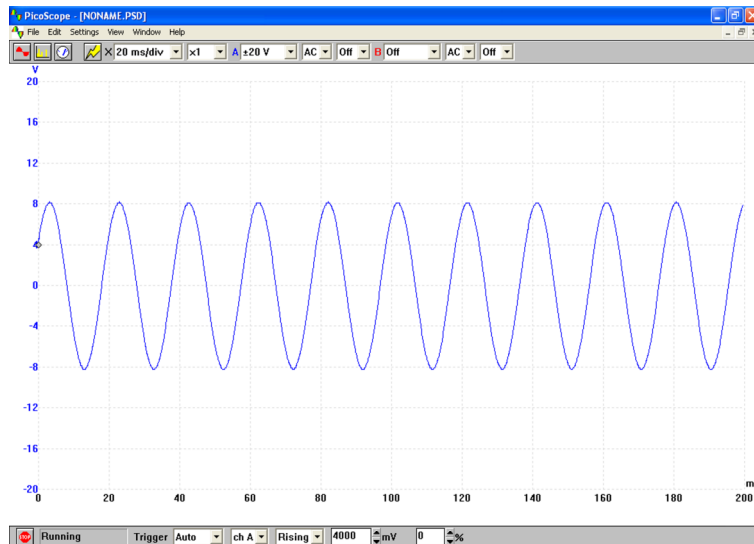

In this trace:

Timebase = 20ms/div,

- the time scale (horizontal axis) is marked off in 20 ms divisions;
- the trace is 'squashed' horizontally, but shows a greater time duration.

Voltage sensitivity = ± 20 V,

- the maximum possible voltage range (vertical axis) is +20V to -20V;
- the trace is 'squashed' vertically, but shows a greater possible voltage range.

Trigger - now 4000 mV, and so the trace does not start until the signal on channel A reaches 4000mV (4V)

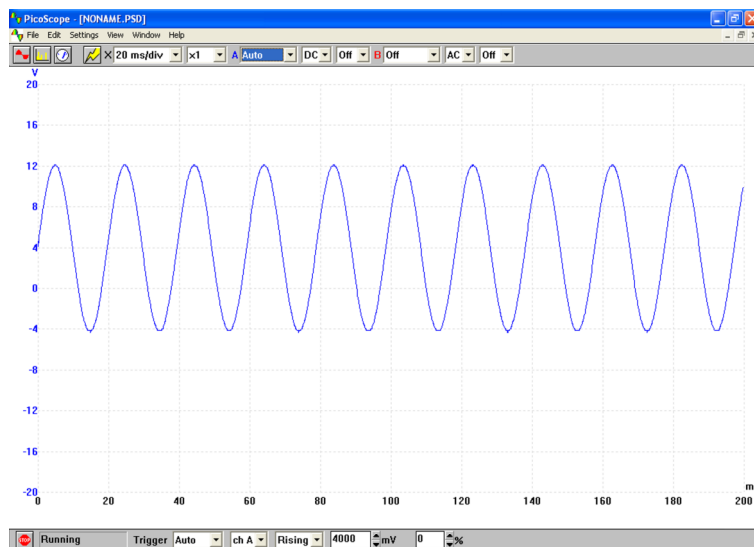

In this trace, the settings are identical except that the DC option is chosen. The trace now reveals that, in addition to the AC signal, there is a steady DC component of +4V. The trace is centred vertically on 4V, not 0V. The AC component makes it swing by ± 8 V, i.e. between -4V and +12V.

Version control

Introduction to motors, generators and hybrid

31 10 2012

Adapted from previous LK8821 curriculum to include hybrid vehicle curriculum...

New worksheet four added

Worksheets 3,5 amended

BOM updated to new LK7445 kit

Details of Matrix PSU's and multimeter updated